

Re. No.	DESCRIPTION	DATE	DS.	CH.	AP.
△					
△					
△					

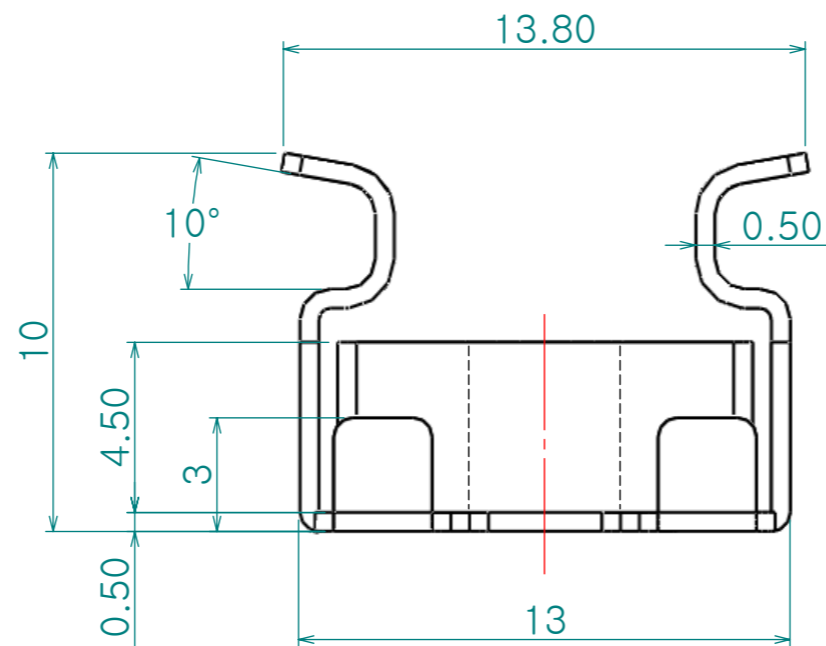
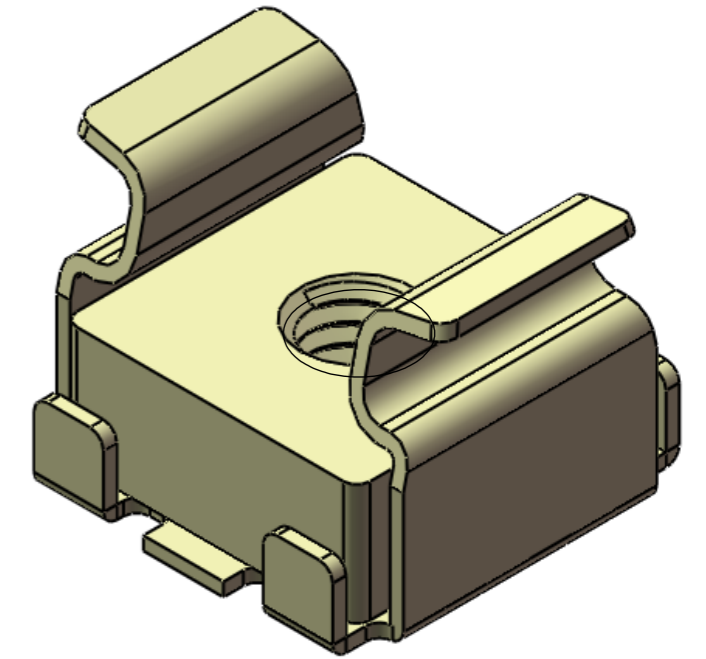
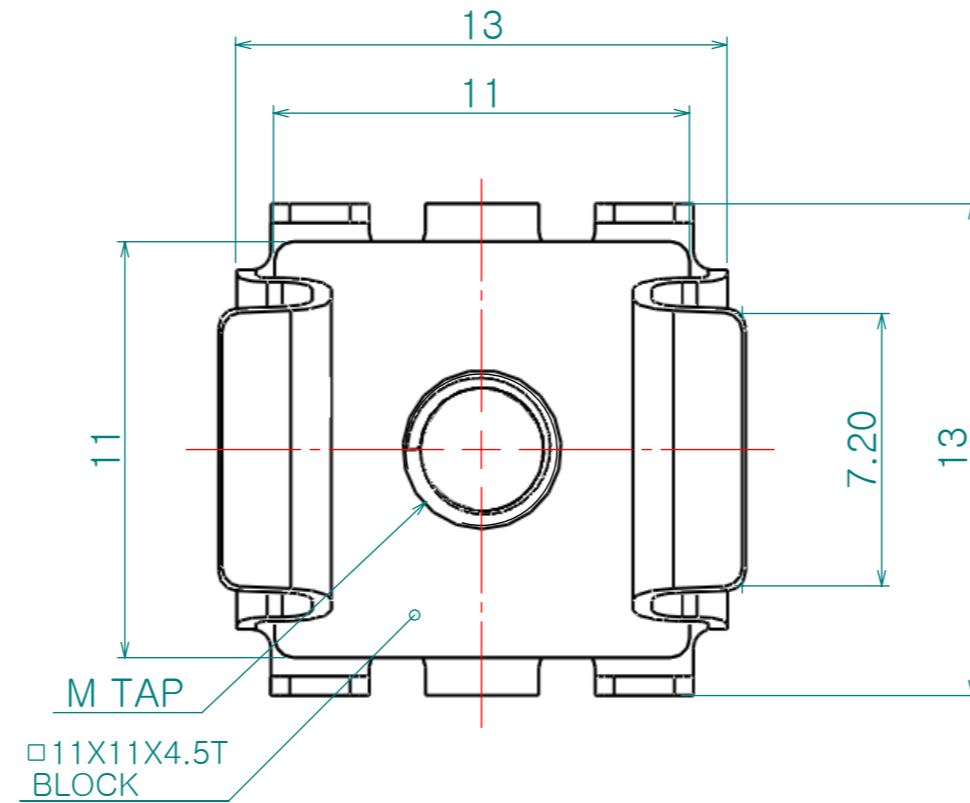
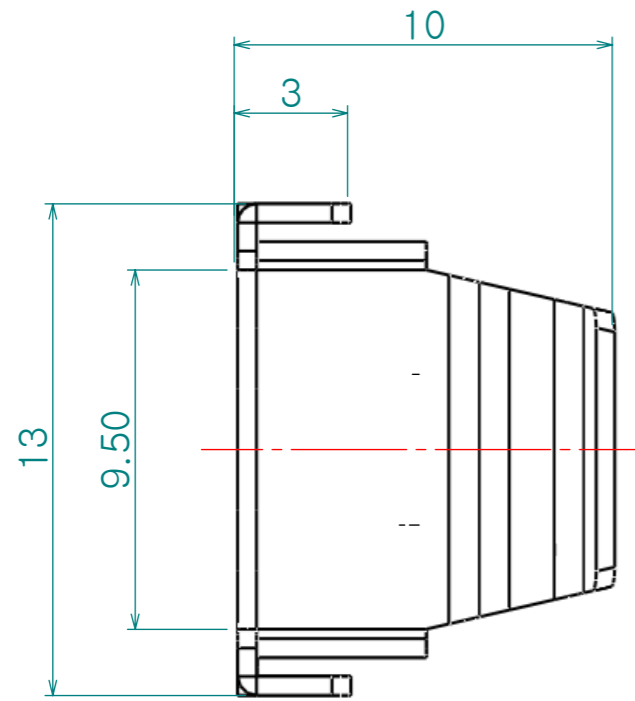
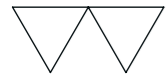

제품명	M	재질	표면처리
CD- 002-M4	M4 TAP	STEEL	아연도금 니켈도금
CD- 002-M5	M5 TAP		
CD- 002-M6	M6 TAP		

Note

- 1. 특징 :
- 2. 용도 :

Dimension (mm)	Precision	Material	Dwg. No.	QTY
0.5~3	±0.05	STEEL	Part Name.	*EA
3~6		아연도금		CLIP NUT
6~30	±0.1	Revision	Sheet Size	-
30~120	±0.15			-
120~315	±0.2	Date	Designed by	5:1
315~1000	±0.3	2010-04-11	Shin S H	Model No.
1000~2000	±0.5	Checked by	Approved by	
KS B 0412에 준함		Hardware		