

Re. No.	DESCRIPTION	DATE	DS.	CH.	AP.
△					
△					
△					

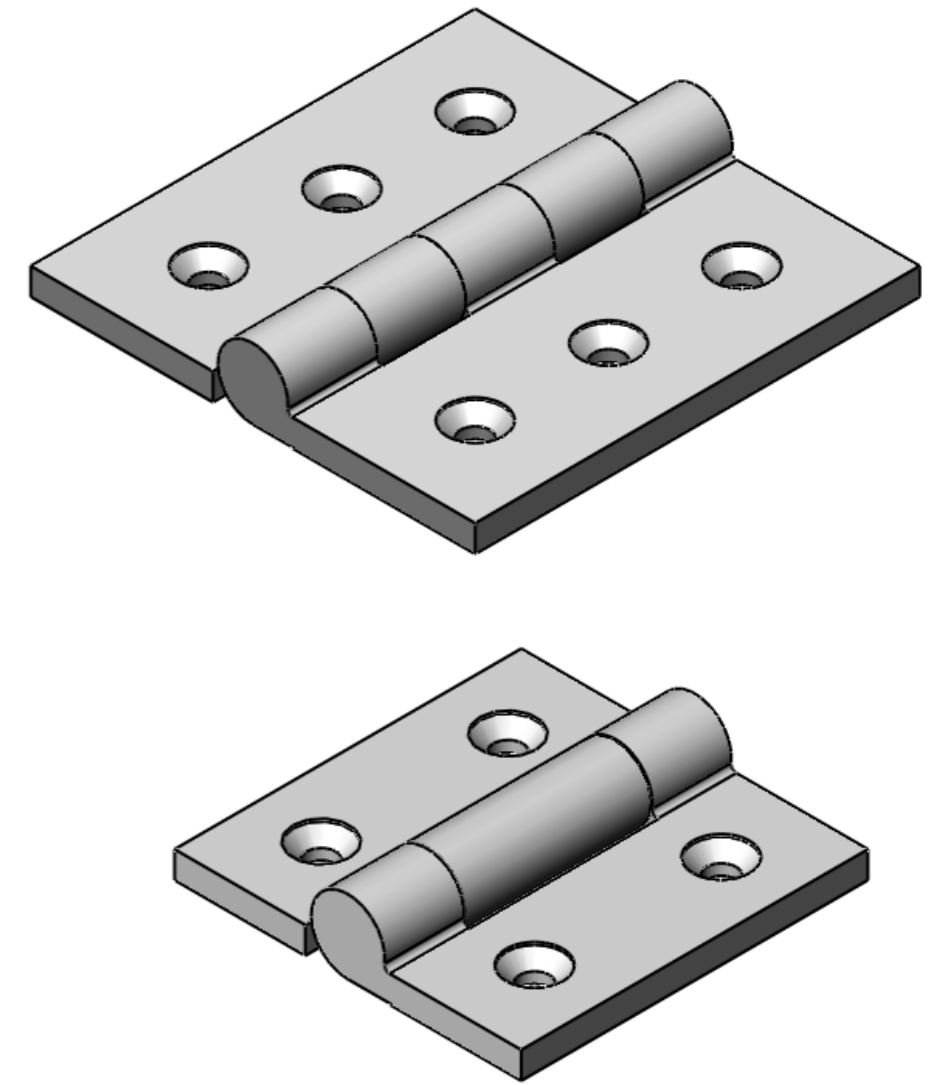
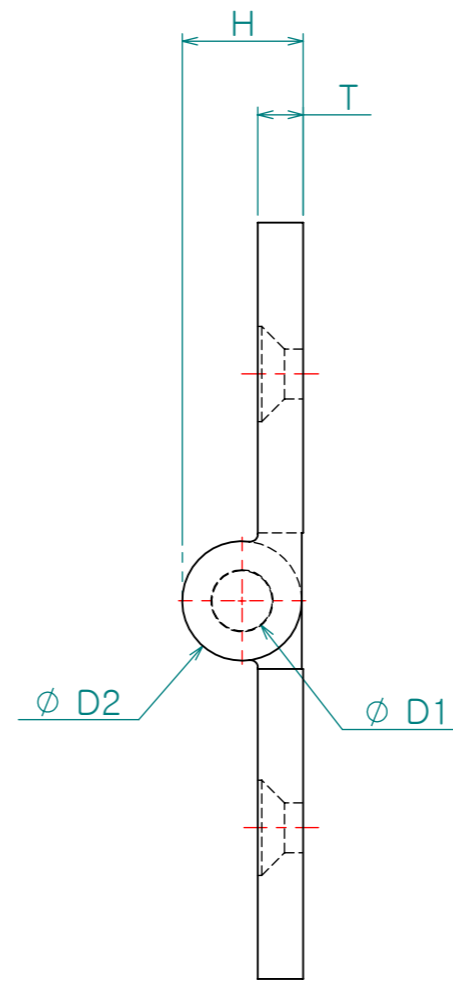
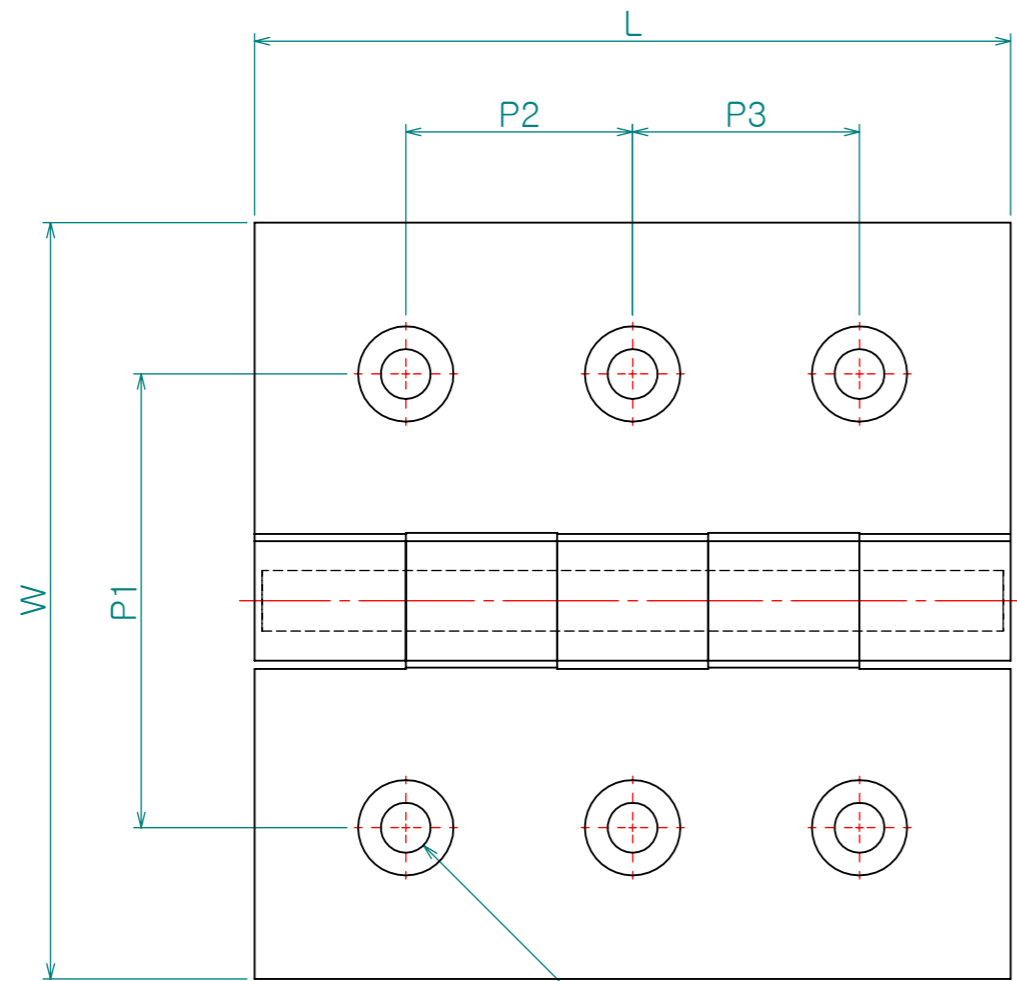
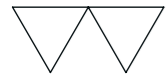

N-M COUNTERSINK

제품명	L	W	P1	P2	P3	T	H	D1	D2	N-M
CH- 005-1	50	50	35	20	-	5	14	6	14	4-4
CH- 005-2	65	65	40	35	-	5	14	6	14	4-5
CH- 005-3	75	75	50	40	-	6	16	8	16	4-6
CH- 005-4	100	100	60	30	30	6	16	8	16	6-6

Note

- 1. 특징 :
- 2. 용도 :

Dimension (mm)	Precision	Material	Dwg. No.	QTY
0.5~3	±0.05	ST304	Part Name.	**
3~6		Finish		Weight
6~30	±0.1	광택연마	**	-
30~120	±0.15	Revision	Ass'y Name	Scale
120~315	±0.2	-	**	1:1
315~1000	±0.3	Date	Model No.	
1000~2000	±0.5	2010-02-19	CH- 005	
KS B 0412에 준함		Designed by	Hardware	
		Shin S H		
		Checked by		
		Approved by		