

Re. No.	DESCRIPTION	DATE	DS.	CH.	AP.
△					
△					
△					

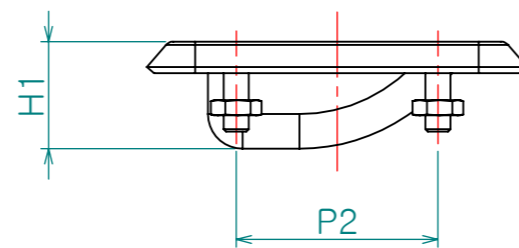
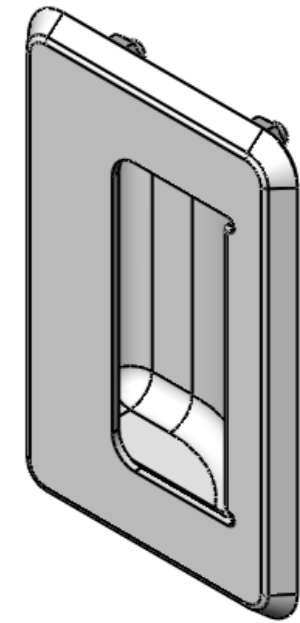
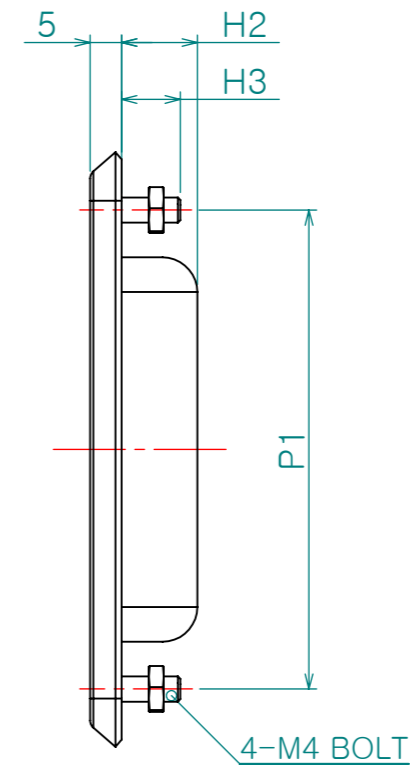
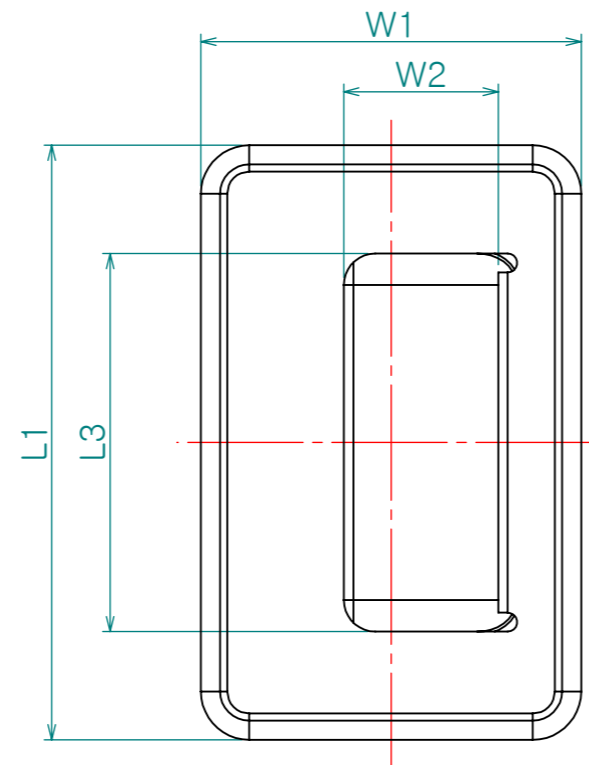
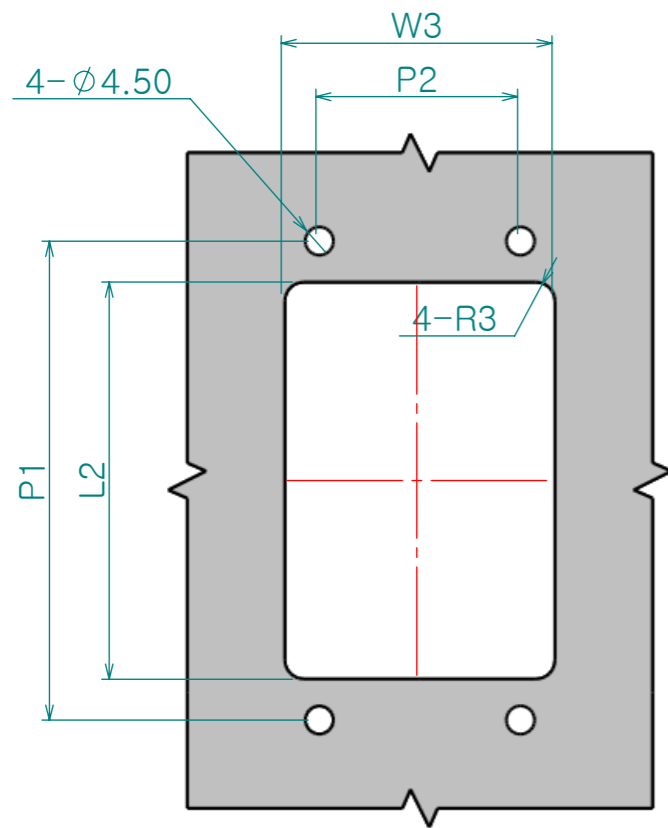

※ PANEL DRILLING MIMENSIONS

제품명	L1	L2	L3	W1	W2	W3	H1	H2	H3	P1	P2
CA-1011-1	94	63	61	60	25	43	17	12	9	76	32
CA-1011-2	109.5	73	70	64	25	42	19.5	14.5	9	88	38
CA-1011-3	138	99	95	88	25	65	26	21	9.5	110	65

Note

- 1. 특징 :
- 2. 용도 :

Dimension (mm)	Precision	Material	Dwg. No.	QTY	
0.5~3	±0.05	STS304	Part Name.	*EA	
3~6		Finish		Weight	
6~30	±0.1	HAIRLINE	**	-	
30~120	±0.15	Revision	Sheet Size	Scale	
120~315	±0.2	-	A3	1:1.2	
315~1000	±0.3	Date	Designed by	Model No.	
1000~2000	±0.5	2010-02-10	Shin S H		CA-1011
KS B 0412에 준함		Checked by	Approved by		